

Agilent OmniBER OTN Family

OmniBER OTN
communications
performance analyzer

Installation Manual

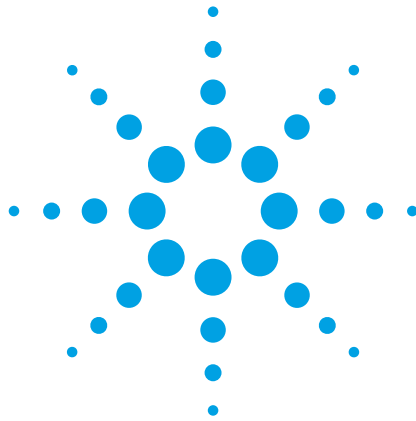

Agilent Technologies



Agilent OmniBER Family OmniBER OTN

J7231B & J7232A Models

Installation Manual



Agilent Technologies

Notices

© 2003 Agilent Technologies UK Limited

No part of this manual may be reproduced in any form or by any means (including electronic storage and retrieval or translation into a foreign language) without prior agreement and written consent from Agilent Technologies UK Limited as governed by international copyright laws.

Sales and Service Offices

An up-to-date list of Agilent Offices is available through the Agilent Website at URL:

<http://www.agilent.com>

Manual Part Number

J7230-90054

Edition

First edition, September 2003

Printed in UK

Agilent Technologies UK Limited
Data Networks Division
South Queensferry, West Lothian, Scotland
EH30 9TG

Warranty

The material contained in this document is provided "as is," and is subject to being changed without notice in future editions. Further, to the maximum extent permitted by applicable law, Agilent Technologies disclaims all warranties of merchantability and fitness for a particular purpose. Agilent Technologies shall not be liable for errors or for incidental or consequential damages in connection with the furnishing, use, or performance of this document or of any of the products to which it pertains. Should Agilent Technologies have a written contract with the user and should any of the contract terms conflict with these terms the contract terms shall control.

Technology Licenses

The hardware and/or software described in this document are furnished under a license and may be used or copied only in accordance with the terms of such license.

Restricted Rights Legend

If software is for use in the performance of a U.S. Government prime contract or subcontract, Software is delivered and licensed as "Commercial computer software" as defined in DFAR 252.227-7014 (June 1995), or as a "commercial item" as defined in FAR 2.101(a) or as "Restricted computer software" as defined in FAR 52.227-19 (June

1987) or any equivalent agency regulation or contract clause. Use, duplication or disclosure of Software is subject to Agilent Technologies' standard commercial license terms, and non-DOD Departments and Agencies of the U.S. Government will receive no greater than Restricted Rights as defined in FAR 52.227-19(c)(1-2) (June 1987). U.S. Government users will receive no greater than Limited Rights as defined in FAR 52.227-14 (June 1987) or DFAR 252.227-7015 (b)(2) (November 1995), as applicable in any technical data.

Safety Notices

CAUTION

A **CAUTION** notice denotes a hazard. It calls attention to an operating procedure, practice, or the like that, if not correctly performed or adhered to, could result in damage to the product or loss of important data. Do not proceed beyond a **CAUTION** notice until the indicated conditions are fully understood and met.

WARNING

A **WARNING** notice denotes a hazard. It calls attention to an operating procedure, practice, or the like that, if not correctly performed or adhered to, could result in personal injury or death. Do not proceed beyond a **WARNING** notice until the indicated conditions are fully understood and met.

In This Manual...

You will find the information required to install your instrument, plus safety and terminology information.

1 Introduction

This chapter provides a brief description of the product and also all safety requirements the user should be aware of when using the instrument.

2 Installation (Getting Started)

This chapter provides general information on how to install and connect up the instrument.

3 ETSI/ANSI Terminology

This chapter provides a table explaining the equivalent SDH/SONET terms.

Conventions Used in this Manual

The conventions used in this manual to illustrate instrument keys and display information are as follows:

- <Menu>** This is an example of a hardkey. Hardkeys (located to the right of the display) are used to give access to different sets of instrument settings, or select dedicated instrument functions.
- Menu Items** Menu items appear in text in **bold** with the greater than (>) symbol separating each menu level. For example, if you are instructed to choose Errors and Alarms from the Test Functions menu, it appears as **Test Functions > Errors and Alarms**.
- Field Items** Field items you can select will appear in **bold**, for example select **Signal Rate** field.
- Drop Down Lists** The item you must select from a drop down list is also shown in bold. For example, select **Signal Rate** field and choose **STM-1** or **OC-3** from the drop down list.

Contents

1 Introduction

Product Description	8
Option Guide	10
General Information	15
Responsibilities of the Customer	15
Storage and Shipment	17
Safety Information	19
Safety Symbols	20
Optical Connector Safety Information	22
Additional Precautions for Service Engineers	25
Avoiding Problems When Making Measurements	27
Operators Maintenance	28
Statement of Compliance	31
Electromagnetic Compatibility	32
Declaration of Conformity	32

2 Installation (Getting Started)

Preparation	34
Initial Inspection	34
Operating Environment	34
Preparation for Use	35
Rack Mounting the Instrument	39
Operation Checks on Delivery	40
Side Panel Tour	48
Optical In/Out Ports and Electrical Test Ports	48
OTN/SONET/SDH Optical Out Ports	48
OTN/SDH/SONET Optical In Ports	49
Clock Ports/Eye Clock Ports	50
DCC/GCC Port and Trigger Ports	51
SONET/SDH Electrical Test Ports	52
PDH/DSn Ports	52

Jitter Input/Output Connectors and Binary Interfaces 52

Connectors at Base of Side Panel 53

Rear Panel Tour 55

Instrument Reboot (Cold Start) 56

3 ETSI/ANSI Terminology

ETSI/ANSI Conversion and Equivalent Terms 58

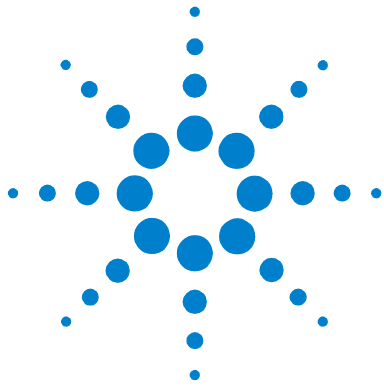

1 Introduction

Product Description	8
Option Guide	10
General Information	15
Safety Information	19
Optical Connector Safety Information	22
Additional Precautions for Service Engineers	25
Avoiding Problems When Making Measurements	27
Operators Maintenance	28
Statement of Compliance	31

This chapter provides a brief description of the product and also all safety requirements you should be aware of when using the instrument.



Product Description

The Agilent OmniBER OTN provides all the test capability you need to test the performance of today's high-capacity transmission systems and networks, in one portable package.

OmniBER OTN J7231B



- Global test coverage (SONET, SDH) and optical transport network (OTN) G.709 testing at 10.71 Gb/s, including the availability of a range of standard and concatenated mappings
- Jitter testing at all optical rates up to 10.7 Gb/s, including Jitter Tolerance and Jitter Transfer
- Wander testing at all optical rates up to 10 Gb/s, including Wander Tolerance
- All standard error and alarm measurements, plus optical power, frequency, service disruption time, pointer movements and performance analysis
- Simultaneous all-channel testing
- Thru-mode monitoring
- Comprehensive OTN/SONET/SDH overhead testing
- Broad range of graphical results tools
- Comprehensive online help facilities including Online Help, context-sensitive help for each control field and facility for adding your own help documents

See “[Option Guide](#)” on page 10, for more product details.

OmniBER OTN J7232A



- Global test coverage (SONET, SDH), testing up to 2.5 Gb/s, including the availability of a full range of standard and concatenated mappings, GFP/LAPS/Ethernet/VT/TU payload testing and DS1/3 and 2/34/140 Mb/s service mappings
- All standard error and alarm measurements, plus optical power, frequency, service disruption time, pointer movements and performance analysis
- Simultaneous all-channel testing (up to 192 STSs/AUs)
- Thru-mode monitoring
- Comprehensive SONET/SDH overhead testing
- Broad range of graphical results tools
- Comprehensive online help facilities including Online Help, context-sensitive help for each control field and facility for adding your own help documents

See “[Option Guide](#)” on page 10, for more product details.

Option Guide

This guide explains the features offered with the instrument mainframe and its associated options.

For more information, see:

- [“Mainframe Test Rate Capability”](#) on page 11
- [“Optical Interfaces”](#) on page 11
- [“Optical Transport Network Testing”](#) on page 12
- [“Next Generation SONET/SDH Testing”](#) on page 12
- [“PDH/DSn Testing/Electrical Interfaces”](#) on page 12
- [“Optical Connectors \(Product Options\)”](#) on page 13
- [“Recommended Accessories”](#) on page 13
- [“Accessories”](#) on page 13

Mainframe Test Rate Capability

Mainframe	Optical Test Interfaces
J7231B BER and Jitter Tester (10 Gb/s)	OC-1, OC-3, OC-12, OC-48, OC-192 STM-0, STM-1, STM-4, STM-16, STM-64
J7232A BER Tester (2.5 Gb/s)	OC-1, OC-3, OC-12, OC-48 STM-0, STM-1, STM-4, STM-16
J7231B-004/J7232A-004	Side mounted connectors
J7231B-005/J7232A-005	Rear mounted connectors

Optical Interfaces

	Wavelength	Option
Optical Interfaces operating at 2.5 Gb/s. Includes 52 and 155 Mb/s electrical interfaces.	52-2488 Mb/s test interfaces not required	100*
	1310 nm optical transmitter	104
	1550 nm optical transmitter	105
	1310/1550 nm optical transmitter	106
Optical Interfaces operating at 10 Gb/s and 10.71 Gb/s	1550 nm optical transmitter	108*

* Not available for J7232A instrument.

Optical Transport Network Testing

Option for OTN G.709 testing. Not available for J7232A instrument.

	Option
OTU2 testing at 10.71Gb/s	112

Next Generation SONET/SDH Testing

Not available for J7231B instrument.

	Option
Ethernet-over-SONET/SDH via GFP (T&F) and LAPS	320

PDH/DSn Testing/Electrical Interfaces

	Option
DSn/PDH framed/unframed testing plus DSn/PDH electrical interfaces	012

Mixed Mappings

Not available for J7232A instrument.

Adds	Mixed mappings option
Firmware only option that adds mixed mappings plus STS-6c, -9c, -24c and VC-4-2c, -4-3c, -4-8c	510

Optical Connectors (Product Options)

Connector	Option
FC/PC Adapters fitted on all optical interfaces	609
SC Adapters fitted on all optical interfaces	610
ST Adapters fitted on all optical interfaces	611

Recommended Accessories

Connectors Alternative optical connectors are available for your product; order the appropriate J7283A (FC/PC), J7284A (SC) or J7285A (ST) accessory (connector). The number of connectors required for your product is shown below.

	J7283A (FC/PC)	J7284A (SC)	J7285A (ST)
J7231B/J7232A with option 104/105	4	4	4
J7231B/J7232A with option 106	5	5	5
J7231B with option 100	2	2	2

Warranty and Service Plans

Terms and conditions of the applicable warranty for this product are contained in the sales and related documentation supplied separately.

Please contact your nearest Agilent Technologies Sales Office for further information on warranty and extended warranty options.

For access to Agilent Product information and sales/service contacts, please visit <http://www.agilent.com>.

Accessories

J7821A: Hard transit case (for J7231B/J7232A option 004)

Optical Adapters and Cables

J7281A: DCC port converter cable: 9-pin miniature D-type to 37-pin D-type (RS-449, female)

J7283A: FC/PC optical connector (exchangeable)

J7284A: SC optical connector (exchangeable)

J7285A: ST optical connector (exchangeable)

General Information

Responsibilities of the Customer

The customer shall provide:

- 1 Access to the products during the specified periods of coverage to perform maintenance.
- 2 Adequate working space around the products for servicing by Agilent personnel.
- 3 Access to and use of all information and facilities determined necessary by Agilent to service and/or maintain the products. (Insofar as these items may contain proprietary or classified information, the customer shall assume full responsibility for safeguarding and protection from wrongful use.
- 4 Routine operator maintenance and cleaning as specified in the Agilent Operating and Service Manuals.
- 5 Consumables such as paper, disks and cleaning materials.

Certification

Agilent Technologies certifies that this product met its published specifications at the time of shipment from the factory. Agilent Technologies further certifies that its calibration measurements are traceable to the United States National Bureau of Standards, to the extent allowed by the Bureau's calibration facility and to the calibration facilities of other International Standards Organization members.

Assistance

Product maintenance agreements and other customer assistance agreements are available for Agilent products.

Instrument Serial Number

Attached to the **rear panel** of the instrument is a serial number plate. The serial number plate has a two letter reference denoting country of origin (GB = Great Britain) and an eight digit serial number. The serial number is unique to each instrument and should be quoted in all correspondence with Agilent, especially when ordering replacement parts.

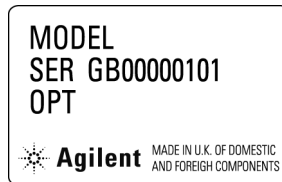

Serial Number Plate

Storage and Shipment

The instrument may be stored or shipped in environments within the following limits:

Temperature

-40 to +75 degC

Altitude

Up to 3000 meters (9840 feet)

The instrument should also be protected from temperature extremes which could cause condensation within the instrument.

Repackaging for Shipment

Shipping to Service Centers. You can re-use the packaging, if in its original condition, for onwards transportation and to return the instrument for calibration or servicing. If the instrument is being returned to Agilent for servicing, attach a tag indicating the type of service required, return address, model number, and full serial number. In any correspondence, refer to the instrument by model number and full serial number.

A hard transit case is available as an optional accessory. (Order item no. **J7821A**: Hard transit case for **J7231B/J7232A**). The hard case should always be used when transporting the instrument in an aircraft hold.

CAUTION

The instrument cover should always be fitted when transporting the instrument.

Other Packaging. The following general instructions should be followed when repackaging with commercially available materials:

- Wrap instrument in heavy paper or plastic. If the instrument is being shipped to Agilent, attach a tag indicating the type of service required, return address, model number and full serial number.
- Use a strong shipping container. A double wall carton made of 350 pound test material is adequate.
- Use a layer of shock absorbing material 70 to 100 mm (3 to 4 inch) thick, around all sides of the instrument to provide firm cushioning and prevent movement inside the container. Protect the Front Panel controls and Top Panel connectors with cardboard.
- Seal shipping container securely.
- Mark shipping container FRAGILE to ensure careful handling.
- In any correspondence, refer to instrument by model number and full serial number.

Weight and Dimensions

Weight	J7231B 22.7 kg (50 lb), J7232A 17.2 kg (38 lb)
Dimensions	300 x 365 x 450 mm (11.75 x 14.5 x 17.75 in) (height x width x depth)

Safety Information

The following general safety precautions must be observed during all phases of operation, service, and repair of this instrument. Failure to comply with these precautions or with specific warnings elsewhere in this manual violates safety standards of design, manufacture, and intended use of the instrument. Agilent Technologies assumes no liability for the customer's failure to comply with these requirements.

WARNING

DO NOT operate damaged equipment. Whenever it is possible that the safety protection features built into this product have been impaired, either through physical damage, excessive moisture, or any other reason, REMOVE POWER and do not use the product until safe operation can be verified by service-trained personnel. If necessary, return the product to an Agilent Sales and Service Office for service and repair to ensure the safety features are maintained.

For safety information, read the following sections:

- [“Safety Symbols”](#) on page 20
- [“Optical Connector Safety Information”](#) on page 22
- [“Laser Warning Symbols”](#) on page 24
- [“Additional Precautions for Service Engineers”](#) on page 25
- [“ESD Precautions”](#) on page 25
- [“Avoiding Problems When Making Measurements”](#) on page 27
- [“Operators Maintenance”](#) on page 28

Safety Symbols

The following symbols on the instrument and in the user documentation indicate precautions you should take to maintain safe operation of the instrument.

Caution: refer to accompanying instructions in user documentation.

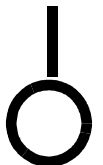
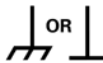

Indicates the field wiring terminal that must be connected to earth ground before operating the equipment - protects against electrical shock in case of fault.

Frame or chassis ground terminal - typically connects to the equipment's metal frame.

Alternating current (AC).

Direct current (DC).

This symbol indicates the position of the operating switch for 'On' mode.

This symbol indicates the position of the operating switch for 'Off' mode.

Indicates hazardous voltages.

This symbol indicates that a device, or part of a device, may be susceptible to electrostatic discharges (ESD) which can result in damage to the product. Observe ESD precautions given on the product, or its user documentation, when handling equipment bearing this mark.

WARNING

Warning denotes a hazard. It calls attention to a procedure, which if not correctly performed or adhered to could result in injury or loss of life. Do not proceed beyond a warning note until the indicated conditions are fully understood and met.

CAUTION

Caution denotes a hazard. It calls attention to a procedure, which if not correctly performed or adhered to could result in damage to or destruction of the instrument. Do not proceed beyond a caution note until the indicated conditions are fully understood and met.



Indicates that a laser is fitted. The user must refer to the manual for specific Warning or Caution information to avoid personal injury or damage to the product.

Optical Connector Safety Information

WARNING

To prevent personal injury, avoid use that may be hazardous to others, and maintain the instrument in a safe condition. Ensure the information given below is reviewed before operating the instrument.

For your protection, review all laser information given in this manual before installing or using the instrument:

- [“Laser Product Classification”](#) on page 23
- [“Connecting or Disconnecting Optical Cables”](#) on page 23
- [“Laser Warning Symbols”](#) on page 24
- [“Avoiding Optical Receiver Overload”](#) on page 24
- [“Additional Precautions for Service Engineers”](#) on page 25
- [“Cleaning Optical Connectors”](#) on page 28

Laser Product Classification

All optical modules are classified as Class I (non-hazardous) laser product in the USA which complies with the United States Food and Drug Administration (FDA) Standard 21 CFR Ch.1 1040.10, and are classified as Class 1 (non-hazardous) laser products in Europe which complies with EN 60825-1 (1994) + A11 1996 +A2 2001 and elsewhere with IEC 60825-1 (2001-08) Ed. 1.2.

Connecting or Disconnecting Optical Cables

CAUTION



When connecting or disconnecting, ensure you are grounded or make contact with the metal surface of the Mainframe with your free hand to bring you, the module, and the mainframe to the same static potential.

Modules may be susceptible to ESD while the module is installed in the mainframe. You should read the additional ESD information provided in this manual before servicing the instrument.

NOTE

The connectors available depend on the options fitted to your instrument. See the **Instrument Tour** in the **Getting Started** section of the Online Help for more information on connectors.

To avoid hazardous exposure to laser radiation, observe the following during system operation:

- ALWAYS DEACTIVATE THE LASER BEFORE CONNECTING OR DISCONNECTING OPTICAL CABLES.
- When connecting or disconnecting optical cables between the instrument and device-under-test, observe the connection sequences given below.

Connecting: Connect the optical cable to the input of the device-under-test before connecting to any of the instrument's **Optical Out** connectors. Maximum power levels are printed on the connector panels adjacent to the port.

BEFORE connecting any signal to the **Optical In** ports ensure that sufficient external attenuation is inserted in the signal path so that the power level is within the 'Operating Range' for the port. Also ensure that any signal transient condition **never** exceeds the maximum stated limit for that port.

Disconnecting: Disconnect the optical cable from the **Optical Out** connector before disconnecting from the device-under-test. Always close the fiber optic connector dust caps over the laser aperture.

- NEVER examine or stare into the open end of a broken, severed, or disconnected optical cable when it is connected to one of the instrument's Optical Out connectors.
- Arrange for service-trained personnel, who are aware of the hazards involved, to repair optical cables.

Laser Warning Symbols

The instrument's connector panel is labelled with the following:

CLASS 1 LASER PRODUCT

CLASS 1 LASER PRODUCT translates as follows:

Finnish - LUOKAN 1 LASERLAITE

Finnish/Swedish - KLAS 1 LASER APPARAT

This label indicates that the radiant energy present in this instrument is non-hazardous.

Avoiding Optical Receiver Overload

Check that you do not overload the receiver when connecting an optical transmitter to an optical receiver. This applies to elements under test and also the receiver input ports. To avoid optical receiver overload, complete the following:

- Check for Status messages on the instrument display warning of overload conditions.
- Check the printed output/input power level information on the connector panel:
 - a Tx Optical Out ports:** Maximum available output power.

- b Rx Optical In ports:** Damage level: power level at which the receiver is damaged and maximum operating input power for signals applied to the receiver. When performing tests, it is recommended that you drive the optical receiver with a signal that has an average power in the middle of the receiver's operating range (mid-way between the upper and lower levels).

Additional Precautions for Service Engineers

DO NOT substitute parts or modify equipment. Because of the danger of introducing additional hazards, do not install substitute parts or perform any unauthorized modification to the product. Return the product to an Agilent Sales and Service Office for service and repair to ensure the safety features are maintained.

DO NOT service or adjust the instrument while alone. Under certain conditions, dangerous voltages may exist even with the equipment switched off. To avoid dangerous electrical shock, do not attempt internal service or adjustment unless another person, capable of rendering first aid and resuscitation, is present.

For more information, see: "[Safety Information](#)" on page 19.

ESD Precautions

The instrument contains components sensitive to electrostatic discharge (ESD). The smallest static voltage most people can feel is about 3500 volts. It takes less than one tenth of that (about 300 volts) to destroy or severely damage static sensitive circuits. Often, static damage does not immediately cause a malfunction but significantly reduces the component's life.

To prevent component damage, follow the handling precautions below.

- Keep the assembly in its conductive storage box/bag when not installed in the Mainframe. Save the box/bag for future storage of the assembly.

- Before handling the assembly, select a work area where potential static sources are minimized. Avoid working in carpeted areas and non-conductive chairs. Keep body movement to a minimum. It is recommended that you use a controlled static workstation.
- Avoid touching any components or edge connectors. When you install the assembly, keep one hand in contact with the protective bag as you pick up the assembly with your other hand. Before installing the assembly, ensure that you are grounded or make contact with the metal surface of the mainframe with your free hand to bring you, the assembly, and the mainframe to the same static potential. This also applies whenever you connect or disconnect cables on the instrument.

Avoiding Problems When Making Measurements

Bit errors can occur due to network defects (such as faulty network elements, damaged optical fiber or dust/dirt particles in the fiber connections) or problems with the test environment/setup. Follow the steps below to avoid problems when making measurements.

▶ **To avoid introducing errors when performing tests:**

- 1** Ensure that optical fibers connecting the instrument to the network are not damaged - check that fibers have not been crimped.
- 2** Avoid acute bends in the fiber. Ensure that fibers only have gentle arcs.
- 3** If the instrument is left unattended for a long term test, ensure that the equipment is not in a position where people will disturb the connecting fibers.
- 4** Ensure that all fiber connections are clean and dirt-free. Use a fiberscope to measure the cleanliness of a (unpowered) fiber. A poorly cleaned fiber results in a drop in power. Alternatively, use a power meter (e.g. the instrument's internal power meter) to measure the power at the end of a fiber, the other end of which is connected to the network.
- 5** Before connection is made, always clean the connector ferrule tip with acetone or alcohol using a cotton swab. Dry the connector with compressed air. Failure to maintain cleanliness of connectors is liable to cause excessive insertion loss.
- 6** Ensure that the correct time and date is set on the instrument.
- 7** When performing jitter measurements, allow the instrument to warm-up for 30 minutes prior to use.

Operators Maintenance

WARNING

No operator serviceable parts inside. Refer servicing to qualified personnel. To prevent electrical shock, do not remove covers.

Maintenance appropriate for the operator is:

- Cabinet cleaning - clean the cabinet using a dry cloth only.
- [Cleaning Optical Connectors](#)
- [Cleaning SMA Connectors](#).
- Ensure ventilating fan cover is clean.

Cleaning Optical Connectors

You should clean the optical connectors at regular intervals using the following materials:

Description	Agilent Part Number
Compressed Air Can or Blow Brush	
Isopropyl Alcohol	
Lint-free swab	5080-5400

CAUTION

Do not insert any tool or object into the optical IN or OUT ports of the instrument as damage to or contamination of the optical fiber may result.



To clean the optical connectors

- 1 Disconnect the instrument from the Power Line or switch off the laser transmitter before commencing this cleaning procedure.
- 2 Remove the adapters from the optical IN and OUT ports by flipping back the lever on the optical adapter.

- 3 Using the blow brush with the brush removed blow through the ferrule of the standard flexible connector and the adapter.
- 4 If the optical fiber of the fixed connector requires further cleaning this entails disassembly of the module. This should be carried out only by suitably trained service personnel.
- 5 Apply some isopropyl alcohol to a piece of the cleaning paper and clean the barrel of the adapter. Using a new piece of cleaning paper, clean the face of the adapter. Repeat this operation, using a new piece of cleaning paper each time.
- 6 Use a blow brush or compressed air to remove any particles of cleaning paper which may be present.
- 7 These procedures also apply to any Optical patch cords or attenuators used to avoid subsequent contamination/damage to the Optical ports.

Replace the adapters in the optical connector. Secure in place by clicking the retaining lever back into position.

Cleaning SMA Connectors

Depending on application and environment it may be appropriate to clean the grounding threads of SMA connectors (and SMA semi-rigid links where fitted) using the materials in the following table. This ensures optimum connection and signal screening.

Description	Agilent Part Number
Compressed Air Can or Blow Brush	
Isopropyl Alcohol	
Lint-free Swab	5080-5400

CAUTION

Do not insert any tool or object into the SMA connector ports to avoid damage.

► **To clean the SMA connectors**

- 1** Disconnect the instrument from the power line before commencing this cleaning procedure.
- 2** Apply some isopropyl alcohol to a piece of the clean lint-free cloth and clean the outer threads of SMA bulkhead connectors taking care not to introduce cleaning fluid into center connection.
- 3** Where a unit has SMA semi-rigid links carefully remove ONE of these using an appropriate spanner, taking note of position and orientation. Clean the bulkhead connectors as in step 2 and clean the inside threads of the SMA link taking care not to bend/damage the center connector pin.
- 4** Carefully refit the link taking care not to mis-thread or overtighten, as damage could result in an expensive repair. Always use a torque spanner to refit and set to 0.9 Nm.

Repeat for other SMA links and also any SMA cables used in the test configuration to avoid subsequent contamination of instrument connectors.

Statement of Compliance

This instrument has been designed and tested in accordance with IEC Publication 61010-1 (1990) + A1:1992 + A2(1995) Safety requirements for Electrical Equipment for Measurement, Control and Laboratory Use, and has been supplied in a safe condition. The instruction documentation contains information and warnings which must be followed by the user to ensure safe operation and to maintain the instrument in a safe condition.



The CE mark shows that the product complies with all relevant European legal Directives.

ISM 1-A

This is a symbol of an Industrial Scientific and Medical Group 1 Class A product.

ICES/NMB-001

This ISM device complies with Canadian ICES-001. Cet appareil ISM est conforme à la norme NMB-001 du Canada.



The CSA mark is a registered trademark of the Canadian Standards Association.



Australian EMC Regulations

The C-Tick mark is a registered trademark of the Australian Communications Authority. This signifies compliance with the Australian EMC Framework Regulations under the terms of the Radiocommunications Act of 1992.

Noise Declaration (German)

LpA<70dB

am Arbeitsplatz (operator position)

normaler Betrieb (normal position)

nach DIN 45635 pt.19 (per ISO 7779)

Electromagnetic Compatibility

This product conforms with the protection requirements of European Council Directive 89/336/EEC for Electromagnetic Compatibility (EMC).

The conformity assessment requirements have been met using the Technical Construction File route to compliance, using EMC test specifications EN 55011:1991 (Group 1, Class A) and EN 50082-1:1992.

In order to preserve the EMC performance of the product, any cable which becomes worn or damaged must be replaced with the same type and specification

If this instrument is subjected to ESD discharges whilst performing measurements occasional erroneous jitter hits or bit errors may be recorded.

Declaration of Conformity

A Declaration of Conformity is provided on the CD-ROM shipped with your instrument.



2 Installation (Getting Started)

Preparation	34
Rack Mounting the Instrument	39
Operation Checks on Delivery	40
Side Panel Tour	48
Rear Panel Tour	55
Instrument Reboot (Cold Start)	55

This chapter provides general information on how to install and connect up the instrument, and how to check that the instrument operates correctly on delivery.



Preparation

Initial Inspection

WARNING

To avoid hazardous electrical shock, do not perform electrical tests when there are signs of shipping damage to any portion of the outer enclosure.

Inspect the shipping container for damage.

If the shipping container or cushioning material is damaged, it should be kept until the contents of the shipment have been checked for completeness and the instrument has been checked both mechanically and electrically.

For procedures for checking operation on delivery See [“Operation Checks on Delivery”](#) on page 40.

If the contents of the shipment are incomplete or if there is mechanical damage or defect, notify the nearest Agilent Office.

If the instrument does not pass the delivery checks notify the nearest Agilent office.

If the shipping container is also damaged, or the cushioning material shows signs of stress, notify the carrier as well as the nearest Agilent office. Keep the shipping materials for the carrier’s inspection. The Agilent office will arrange for repair or replacement without waiting for claim settlement.

Operating Environment

DO NOT operate the product in an explosive atmosphere or in the presence of flammable gasses or fumes.

This instrument may be operated in environments within the following limits:

Temperature: 0 to +40 degC (option 004); 0 to +45 degC (option 005).

Altitude: Up to 3000 m (9840 feet).

Humidity: Up to 90% relative humidity to 40°C, but it should be protected from temperature extremes which may cause condensation.

To ensure adequate cooling, do not obstruct air vents in the instrument cabinet.

CAUTION

This instrument is designed for use in Installation Category II and Pollution Degree 2 per IEC 61010-1 and IEC 60664 respectively.

Ventilation Requirements: When installing the instrument in a cabinet, the convection into and out of the instrument must not be restricted. If the total power dissipated in the cabinet is greater than 800 watts, then forced convection must be used.

This product is suitable for indoor use only.

Preparation for Use

WARNING

If this instrument is not used as specified, the protection provided by the equipment could be impaired. This instrument must be used in a normal condition only (in which all means for protection are intact).

Power Requirements

The instrument requires a power source of 100 to 240 V ac at a frequency between 47 and 63 Hz (nominal).

CAUTION

Mains supply voltage fluctuations should not exceed +/- 10% of the nominal line voltage.

Power consumption: 250VA.

There are no customer replaceable fuses in the instrument.

Connecting to the Power Supply

WARNING

This is a Safety Class I instrument (provided with a protective earthing ground, incorporated in the power cord). The mains plug shall only be inserted in a socket outlet provided with a protective earth contact. Any interruption of the protective conductor inside or outside of the instrument is likely to make the instrument dangerous. Intentional interruption is prohibited.

The mains switch fitted to the instrument is a single pole device and must not be used as the disconnect device. An IEC320 coupler is intended as the main disconnect device. The switch is marked I and 0. The I indicates on and the 0 indicates off. Do not position the instrument such that access to the coupler is impaired.

CAUTION

Before switching on this instrument, make sure that the line supply voltage is in the specified ranges. Range selection is automatic

As the IEC320 coupler is the disconnect device, consideration must be given to the following when installing the instrument in a rack:

- An adequately rated switch (250V, 10A) or circuit breaker (250V, 5A) shall be included in the rack.
- It should be in close proximity to the instrument and within easy reach of the operator.
- It shall be marked as a disconnect device.

Power Cable

WARNING

To avoid the possibility of injury or death, the following precautions must be followed before the instrument is switched on:

- (a) While this is a Class I product, provided with a protective earthing conductor in a power cord, an external chassis earthing terminal has also been provided. This terminal is for use where the earthing cannot be assured. At least an 18AWG earthing conductor should be used in such an instance, to ground the instrument to an assured earth terminal. The external chassis earth terminal is on the rear of the instrument.
- (b) If this instrument is to be energized via an auto-transformer to reduce or increase the line voltage, make sure that the common terminal is connected to the neutral pole of the power source.
- (c) The power cable plug shall only be inserted into a socket outlet provided with a protective ground contact. The protective action must not be negated by the use of an extension cord without a protective conductor (grounding).



Figure 1 Earthing terminal - rear panel

The power cord supplied with each instrument varies with the country of destination. The following figure illustrates the standard power plug and cord configurations that are commonly used. The part number shown beneath each plug is the part number of the appropriate power cord and plug. If the appropriate power cord is not included with the instrument notify the nearest Agilent office and a replacement will be provided.

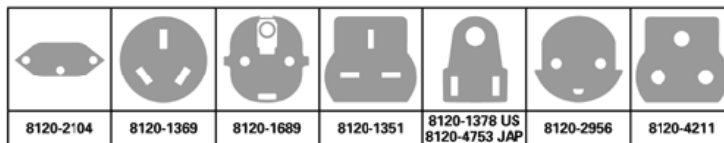

Figure 2 Power cable configurations and part numbers

Removing the Instrument Covers

The instrument covers are a press-fit. To remove them, gently lever them off.

When transporting the instrument, always replace both covers to protect the instrument connectors and display.

Useful Information When Requesting Support

When contacting Agilent Technologies for support it is useful to have the following instrument information available:

- Model Number.
- Serial Number. (on instrument base plate in the format GBXXXXXXXXXX)
- Instrument Options. (Press <Menu>, choose **System** > **Options** then press <Select>.)
- Instrument Firmware Revision. (Press <Menu>, choose **System** > **Options** then press <Select>. Select the **Software** tab.)
- Self Test fail codes and messages. (Press <Menu>, choose **System** > **Self Test** then press <Select>.)

Rack Mounting the Instrument

Option 005 of the instrument is ready to mount directly into a rack. All the hardware required is supplied with this version of the instrument.

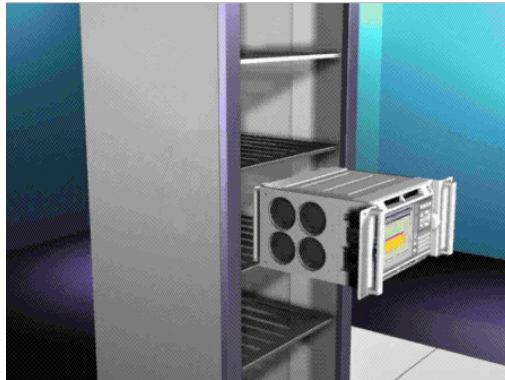

Item (all supplied)	Part Number
Shelf	46101-00146
Captive Nuts (8 off) - for mounting shelf and instrument	0590-0804
Screws (4 off) - for mounting shelf	2680-0278
Dressed Screws (4 off) - for mounting instrument	0570-1366

To Rack Mount the Instrument

- 1 Fit the rack shelf supplied with the instrument to the rack, following the instructions given with the shelf.
- 2 Fit captive nuts (4 off, supplied) to rack uprights.
- 3 Place instrument on shelf.
- 4 Connect power cord and GP-IB cable (if required) *before* sliding the instrument into its final position on the shelf.
- 5 Fit the screws (4 off, supplied) through the flanges into the captive nuts and tighten to a torque setting of 2 Nm.

Operation Checks on Delivery

The following procedures give a quick power-up and back-to-back functional test of the optical interfaces using the optical accessories provided. These checks should be performed by a user or engineer familiar with making optical interface connections.

CAUTION

Safety precautions, care and connection cleanliness must be observed to ensure that the optical connections are not damaged or degraded. Ensure the recommended optical attenuation is present in all optical loopback connections as failure to do so could cause test failure or damage to the optical receivers.

NEVER CONNECT THE OPTICAL OUTPUT DIRECTLY TO OPTICAL INPUT WITHOUT ATTENUATION AS THIS WILL EXCESSIVELY OVERLOAD THE RECEIVER AND COULD CAUSE DAMAGE.

▶ To power-up the instrument

- 1 For information on how to use the instrument and navigate the graphical user interface, refer to the **Quick Reference Guide** (supplied with the instrument).
- 2 Connect the OmniBER OTN to the AC Power Line using the power cord provided and set OmniBER OTN power switch ON (located beside power inlet).
- 3 The fans should start and after a few seconds the display will initialize and indicate the following.

Starting Instrument

Please wait.....

The Agilent Technologies splash screen will then be displayed while the unit completes initialization.

- 4 On completion (approximately 90 seconds), the display will change to the user windows with instrument settings. The instrument is now ready for use. Note that before you make jitter measurements, you should leave the instrument to warm-up for 30 minutes.

NOTE

While running the instrument, a single line of text appears at the bottom of the display. This gives you helpful information relating to the area of the screen that is highlighted. In addition, online help is available on the instrument. If you require assistance at any time press the **<Help>** button on the front panel. This will display the online help.

To return to the normal instrument display press the **<Help>** button again.

Recalling Default Settings

► **To ensure instrument is set to a known state**

- 1 Press **<Menu>**, choose **System > Stored Settings** then press **<Select>**.
- 2 Select **Default** then **Recall**.
- 3 Select **OK** then wait for a few seconds for instrument to reconfigure to the default settings. Recall has completed when the dialog box clears.
- 4 Select **Close**.
- 5 Proceed with the back-to-back functional checks.

Back-to-Back Functional Checks

An optical patch cord and optical attenuators are provided to make an optical connection between the transmit and receive ports for these checks.

Use the 15 dB optical attenuator for up to 2.5 Gb/s interfaces.

Use the 10 dB optical attenuator for the 10/10.7 Gb/s interface.

Remove any dust protectors from the ends of patch cord and attenuator before fitting and make sure the (white) exposed ends are not touched by fingers or otherwise become contaminated.

When making connections ensure full location in port key/notch then tighten/lock by hand depending on the connector type.

2 Installation (Getting Started)

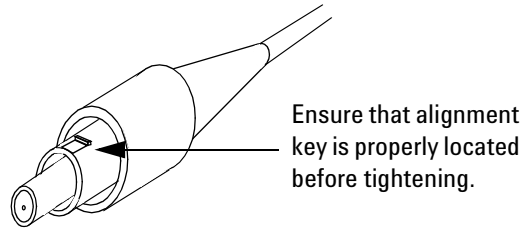

WARNING

Always ensure Optical Output Laser LEDs beside ports are OFF while making/changing optical connections.

Also refer to "Optical Connector Safety Information" on page 22.

- 1 Connect the J7231B OmniBER OTN as shown in below. For J7232A models (up to 2.5 Gb/s only) refer to [Figure 4](#) for Loopback connection and proceed from [step 12](#), ensuring Tx/Rx Coupling is set to ON as in [step 3](#).

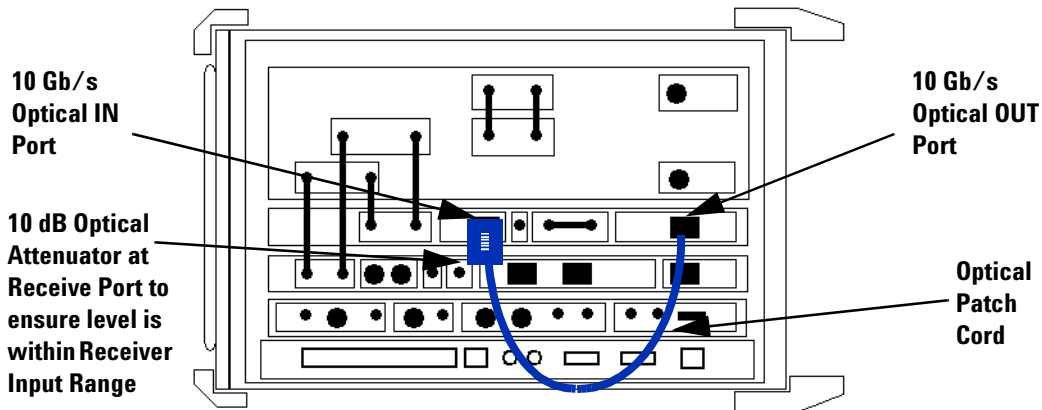

Figure 3 9.95 Gb/s (and 10.71 Gb/s) Loopback Connection

- 2 Press <Menu>, choose Tx/Rx > Transmitter Settings > Physical then press <Select>. Set Laser ON. This enables the

10/10.7 Gb/s Output.

The example below shows the Transmitter Settings for an instrument with OTN option. If this is not fitted the default **Signal Mode** will show **SONET** and **Signal Rate OC-192**.

Signal	
Mode	OTN
Rate	OTU2
Line	
Interface	Optical
Wavelength	1550nm
	<input checked="" type="checkbox"/> Laser On
Clock	
Source	Internal
Format	2Mb/s Clock

Check the laser LED is illuminated at the 9.95/10.71 Gb/s Output Port on the OmniBER OTN's connector panel.

- 3 Press **<Menu>**, choose **Tx/Rx > Coupling** then press **<Select>**. Choose **Copy Tx to Rx** to set Coupling On. Select **Close** to close dialog.

Tx / Rx - Coupling

Copy Tx to Rx Copy Rx to Tx

Coupling On

Switch Coupling Off

Close

- 4 Press **<Smart Test>**, choose **Shortcuts > Trouble Scan** then press **<Select>**. Press **Run/Stop** to begin a measurement.

2 Installation (Getting Started)

- 5 Check that '**No Trouble**' is displayed in the **Results** window to confirm no errors have been detected. If not then refer to "What to Do if the Test Fails" on page 47.

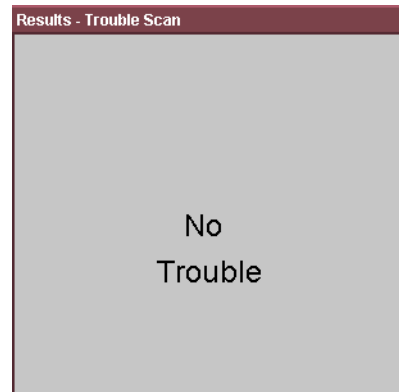

- 6 Press <**Single Error**> button and check that the Errors Led flashes red and some errors accumulate on the **Results - Trouble Scan** window. Then press the <**Run/Stop**> key to stop gating.
- 7 For units with OTN Option, continue with [step 8](#) otherwise proceed to [step 11](#).
- 8 Change the Transmitter Settings **Signal Mode** to **SONET**, **Signal Rate** to **OC-192**.

NOTE

The receiver will automatically set to the same signal rate as the transmitter as Tx > Rx Coupling is On. The graphical display on lower window indicates the overall set-up of transmitter & receiver. Coupling status is shown in left lower corner.

- 9 Check that the laser LED is illuminated at the 9.95/10.71 Gb/s output port on the OmniBER OTN's connector panel.
- 10 Repeat [step 4](#) to [step 6](#) to confirm correct operation.
- 11 Press <**Window**> key to highlight the **Transmitter Settings** page and set the **Laser** to **OFF**.

12 Change/make the following Optical loopback connection to check the 2.5 Gb/s interface as shown in [Figure 4](#).

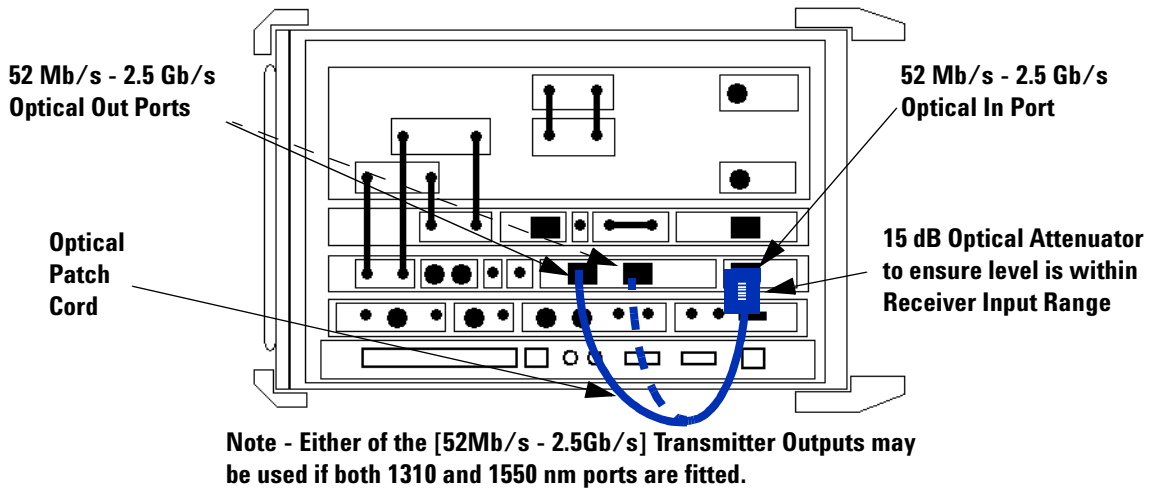

Figure 4 2.5 Gb/s Loopback Connection

- 13** Change/set the Transmitter Settings **Signal Rate** to **OC-48** and set the **Wavelength** to be the same as the transmit port connected in set-up, i.e. **1310nm** or **1550nm**.
- 14** Set the **Laser** to **ON** and check the laser LED is illuminated at the connected 52Mb/s-2.5Gb/s output port on the OmniBER OTN's connector panel.
- 15** Repeat [step 4](#) to [step 6](#) to confirm correct operation.
- 16** Press <Window> key to highlight the **Transmitter Settings** page and set the **Laser** to **OFF**.
- 17** If the instrument has dual **Wavelength** change loopback connection to alternative output port. Otherwise proceed to [step 22](#).
- 18** Change the Transmitter Settings **Wavelength** to be the same as the Transmit Port connected in set-up, i.e. **1310nm** or **1550nm**.

2 Installation (Getting Started)

- 19 Set the **Laser** to **ON** and check the laser LED is illuminated at the connected 52Mb/s-2.5Gb/s output port on the OmniBER OTN's connector panel.
- 20 Repeat [step 4](#) to [step 6](#) to confirm correct operation.
- 21 Press <**Window**> key to highlight the **Transmitter Settings** page and set the **Laser** to **OFF**.
- 22 Change the Transmitter Settings **Signal Rate** to **OC-12** and set the Wavelength to the be same as the Transmit Port connected in set-up.
- 23 Set the **Laser** to **ON** and check the laser LED is illuminated at the connected 5 2Mb/s - 2.5 Gb/s output port on the OmniBER OTN's connector panel.
- 24 Repeat [step 4](#) to [step 6](#) to confirm correct operation.
- 25 Press <**Window**> key to highlight the **Transmitter Settings** window and set the **Laser** to **OFF**.
- 26 Disconnect all loopback connections.

What to Do if the Test Fails

NOTE

Always ensure Optical Output Laser LEDs beside ports are OFF while making/changing optical connections.

- 1 Check all connections and make sure that the correct loopback connection is in place for the interface being checked. Make sure connectors are located in key/notch of the port connectors to ensure full insertion.
- 2 Check transmitter and receiver are set to the same signal rate and that the correct laser is on when test is being run.
- 3 Press <**Smart Test**>, choose **Shortcuts > Optical Power** then press <**Select**>. Check the received signal level is in the green BER measurement power range.
- 4 Ensure all optical connections are clean and fully connected with no sharp bends or twists in the optical patch cord. Check the optical cord and attenuator are not damaged and/or substitute with equivalent
- 5 Power down unit and use recognized cleaning kit to clean connectors before retrying the tests.

If the problem persists then contact your local Agilent sales/service representative.

Side Panel Tour

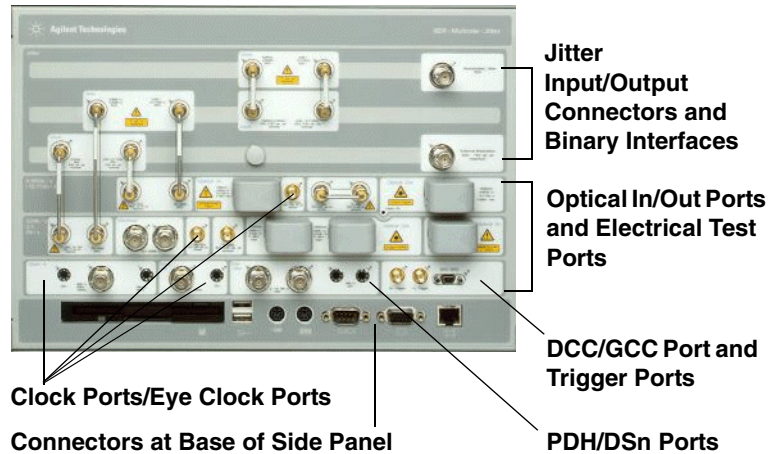

Optical In/Out Ports and Electrical Test Ports

- OTN/SONET/SDH Optical Out Ports
- OTN/SDH/SONET Optical In Ports
- SONET/SDH Electrical Test Ports

OTN/SONET/SDH Optical Out Ports

The Optical Out Ports provide an OTN signal at 10.71 Gb/s, SONET optical signals OC-1, OC-3, OC-12, OC-48, OC-192, and SDH optical signals STM-0, STM-1, STM-4, STM-16, STM-64 at wavelength 1310 and 1550 nm, depending on instrument model and options.

See the technical specifications document for details about the power output and input for the following connectors. Take particular care to note the damage level associated with each input port. To access the technical specifications go to the instrument website:

www.agilent.com/comms/otn_jitter

or www.agilent.com/comms/otn_2-5g

52 Mb/s - 2.5 Gb/s 1310 nm Selectable optical connector (see table below) for a 52 Mb/s to 2.5 Gb/s optical output. The maximum power output is +2 dBm.

52 Mb/s - 2.5 Gb/s 1550 nm Selectable optical connector (see table below) for a 52 Mb/s to 2.5 Gb/s optical output. The maximum power output is +2 dBm.

9.95/10.71 Gb/s, 1550 nm Selectable optical connector (see table below) for a 9.95 Gb/s or a 10.71 Gb/s optical output. The maximum power output is +6 dBm.

OTN/SDH/SONET Optical In Ports

The Optical In ports accept an OTN signal at 10.71 Gb/s, SONET OC-1, OC-3, OC-12, OC-48 and OC-192 and SDH STM-0, STM-1, STM-4, STM-16, STM-64 signals, depending on the model and options fitted.

52 - 2.5/2.5 Gb/s Selectable optical connector (see table below) for a 52 Mb/s to 2.5 Gb/s optical input (OC-1, OC-3, OC-12, OC-48, STM-0, STM-1, STM-4, STM-16 signals).

9.95/10.71 Gb/s Selectable optical connector (see table below) for 9.95/10.71 Gb/s (OC-192/STM-64/OTU2) optical input signals.

Connector	Option
FC/PC Adapters fitted on all optical interfaces	609
SC Adapters fitted on all optical interfaces	610
ST Adapters fitted on all optical interfaces	611

Clock Ports/Eye Clock Ports

TX Eye Clock 9.95 Gb/s and 10.71 Gb/s SMA connector providing a TX Eye Clock signal (at 1/16 of the line rate) which can be used to trigger an oscilloscope when examining data signals.

DS1 Clock In Bantam 100 ohm (nominal) connector for a DS1 BITS external reference clock input.

2 Mb/s, 2 MHz, 10 MHz Clock In BNC 75 ohm (nominal) unbalanced connector for a 2 Mb/s and 2 MHz MTS external clock source input. You can also use this connector to input a 10 MHz clock reference.

2 Mb/s, 2 MHz Clock In Bantam 100 ohm (nominal) connector for a 2 Mb/s and 2 MHz MTS external clock source input.

TX Eye Clock 52 - 2.5 Mb/s SMA connector providing a TX Eye Clock signal (at 1/4 of the line rate) which can be used to trigger an oscilloscope when examining data signals.

2 MHz Clock Out BNC 75 ohm (nominal) unbalanced connector for a 2 MHz MTS clock reference output. Generated relative to the selected transmit reference clock.

DS1 Clock Out Bantam 100 ohm (nominal) connector for a DS1 BITS clock reference output. Generated relative to the selected transmit reference clock.

DCC/GCC Port and Trigger Ports

DCC/GCC Connector R5449 15-way D-type.

Use this port to drop and insert OTN GCC channels (OTU GCC0, ODU GCC1, ODU GCC2), the D1-D3 DCC channel or the D4-D12 DCC channel.

<u>Pin Number</u>	<u>DCC/GCC</u>
1	Rx Data Output (+)
2	Rx Clock Output (+)
3	Signal ground
4	Tx Clock Output (+)
5	Tx Data Input (+)
6	Rx Data Output (-)
7	Rx Clock Output (-)
8	Tx Clock Output (-)
9	Tx Data Input (+)

Rate D1-D3 DCC: 192 kb/s, D4-D12 DCC: 576 kb/s, OTU/ODU GCC0/GCC1/GCC2: 1.3124 Mb/s.

DCC/GCC Port Input Termination 100 ohms differential. The first bit of data inserted will be put into the MSB of the DCC channel. The MSB of the dropped data bytes will be output first. The drop and insert capabilities are independent, meaning the transmit and receive clock rates can be set to different rates. Note that the instrument acts as a DCE (Data Communications Equipment), supplying the clock signal for both drop and insert operation.

Trigger Ports SMA connectors. Use these ports to output transmitter and receiver triggers.

SONET/SDH Electrical Test Ports

SONET/SDH Out BNC 75 ohm unbalanced connector for an STS-1/STM-0 (B3ZS) or STS-3/STM-1 (CMI) electrical output.

SONET/ SDH In BNC 75 ohm unbalanced connector for an STS-1/STM-0 (B3ZS) or STS-3/STM-1 (CMI) electrical input. Input Mode - Terminate or Monitor. Monitor mode conforms to G.772-1993. Monitor Gain - 20 or 26 dB.

PDH/DSn Ports

DS1/2 Mb/s Out Bantam balanced connector for a DS1/E1 Transmit or DS1/E1 Drop signal output. Port is 100 ohm for DS1, 120 ohm for E1. Either this port or the 2-140 Mb/s, DS3 unbalanced Out port can be active for the E1 Transmit function.

DS1/2 Mb/s In Bantam balanced connector for a DS1/E1 Receive or DS1/E1 Insert signal input. Port is 100 ohm for DS1, 120 ohm for E1. Either this port or the 2-140 Mb/s DS3 unbalanced In port can be active for the E1 Receive function.

2-140 Mb/s DS3 Out BNC 75 ohm unbalanced connector for E1, E2, E3, E4, DS3 transmit or E1, E3, E4, DS3 Drop signals. Either this port or the 2 Mb/s balanced Out port can be active for the E1 Transmit function.

2-140 Mb/s DS3 In BNC 75 ohm unbalanced connector for E1, E2, E3, E4, DS3 receive or E1, E3, E4, DS3 Insert signals. Either this part or the 2 Mb/s balanced In port can be active for E1.

Jitter Input/Output Connectors and Binary Interfaces

Demodulated Jitter Output BNC 50 ohm connector providing demodulated jitter output.

External Modulation Input BNC 50 ohm connector for external jitter modulation input. Primarily designed for sinusoidal signals, but can be used with any wave shape. Maximum input level +/- 5V peak AC/DC composite.

Binary Clock and Data Interfaces SMA connectors, providing binary clock and data transmitter and receiver interfaces, which can be configured independently.

Connectors at Base of Side Panel

The following descriptions describe the connectors as they appear from left to right. (Note that on some options the following connectors may be on the rear of the instrument.)

Floppy Disk Drive Accepts 1.44 Mb IBM formatted disks.

USB Two Universal Serial Bus ports for connecting to a printer. The printer may be attached after power-on.

Mouse PS/2 port for connecting a mouse.

Keyboard PS/2 port for connecting an external keyboard. Ensure that keyboard port is used - if connected to mouse PS/2 port in error the instrument will require to be restarted.

RS232 Remote Control port providing following configurations:

- **Controller Type:** Computer and Terminal.
- **Handshaking Protocol:** None, Xon/Xoff and RTS/CTS.
- **Speed:** 300, 600, 1200, 1800, 2400, 4800, 9600, 19200, 38400 baud.
- **Parity:** Odd, Even.
- **Stop Bits:** 1, 2
- **Data Length:** 8, 7 bits.

2 Installation (Getting Started)

VGA Connector for displaying contents of instrument screen on an external display. Ensure that the external display is connected before powering up the instrument.

LAN 10M/100M 10/100 Base-T LAN interface port. Supports remote control of instrument and the downloading of firmware upgrades. Note that to ensure compliance with EN 55011 (1991) a category 5, STP patch lead, RJ45 cable should be used to connect to the LAN port.

Rear Panel Tour



GPIB Allows instrument to be remotely controlled via the GPIB control bus.

External Protective Earth Connect an external earth connection to the instrument at this point.

AC Power Connect the instrument power cord here and set the switch to 1 to turn on and to 0 to turn off.

Instrument Reboot (Cold Start)

An instrument “cold start” routine is provided to reset the instrument in the event of an unplanned hardware or firmware event. A cold start reboots the instrument and restarts the instrument using a default configuration file. Performing a cold start erases existing configuration information. Current menu settings will be lost and the instrument will power up in its default state.

▶ **To perform a cold start**

- 1 Switch the instrument off and wait a few seconds.
- 2 Switch the instrument on and as the instrument boots up, look carefully at the display.
- 3 When the “Press the Menu key for startup options” text is displayed, immediately press the <Menu> key.
- 4 Press 3 on the numeric keypad to select cold start. The unit will then continue with the boot up process.
- 5 When the boot-up procedure is complete, the instrument displays a dialog box with the message: “Instrument reset to default settings.” Press Select to close this window.

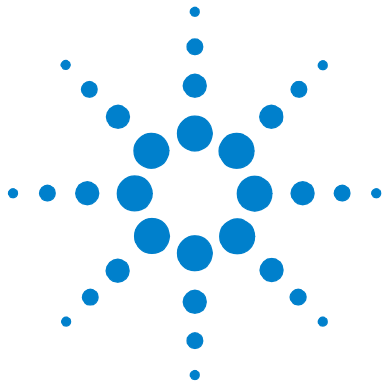

3

ETSI/ANSI Terminology

The terminology used on the instrument display can be ETSI (SDH) or ANSI (SONET). Refer to the table given in this section for an explanation of equivalent SDH/SONET terms.



ETSI/ANSI Conversion and Equivalent Terms

ETSI: European Telecommunications Standards Institute.

ANSI: American National Standards Institute.

ETSI (SDH) Term	ANSI (SONET) Term
AU-3	STS-1 SPE + H1, H2, H3
AU-4	STS-3c SPE + H1, H2, H3
BIP (Bit Interleaved parity)	CV (Code Violation)
High Order Path (HP / HO)	STS Path
I-n Intra Office, (n=STM-n level)	Intermediate Reach (IR)
L-n.1 or L-n.2 long haul	LR long reach
Low Order Path (LP / LO)	VT Path
LP-REI	REI-V
M.S.P	A.P.S
Multiplexer Section (MS)	Line
Multiplexer Section Protection	Automatic Protection Switching
MS-AIS	Line AIS / AIS-L
MS-BIP	Line CV / CV-L
MS-DCC	Line DCC / DCC-L
MS-REI	Line FEBE / REI-L
MS-RDI	Line FERF / RDI-L
Multiplexer Section Overhead	Line Overhead
Network Node Interface	Line Interface
OOF	SEF (severely errored frame defect)
Path AIS / AU-AIS	AIS-P
Path REI / HP REI	REI-P
Path FERF / HP RDI	RDI-P

ETSI (SDH) Term	ANSI (SONET) Term
Path IEC / AU-IEC	IEC-P
Path Overhead	Path Overhead
Regenerator	Repeater
Regenerator Section (RS)	Section
Regenerator Section Overhead	Section Overhead
Remote Alarm Indicator	RAI
RS-DCC	Section DCC (DCC-S)
Section Overhead (SOH)	Transport Overhead (TOH)
S-n.1 or S-n.2 short haul	Short Reach (SR)
SOH	TOH
STM-m	OC-n / STS-n (where $m = n \div 3$ for $m \geq 1$)
STM-0	STS-1
STM-1	OC3c / STS-3c
STM-4	OC-12 / STS-12
STM-16	OC-48 / STS-48
STM-64	OC-192
Tributary Unit (TU)	Virtual Tributary (VT)
TU	VT
TU-11	VT 1.5
TU-12	VT 2
TU-2	VT 6
TU-3	NONE
TU BIP	VT BIP (CV-V)
TU RDI / LP-RDI	RDI-V
TUG	VT Group
TUG2	VT Group (12 columns)

3 ETSI/ANSI Conversion and Equivalent Terms

ETSI (SDH) Term	ANSI (SONET) Term
TUG3	VT Group (86 columns)
TU multiframe	VT superframe
TU PATH AIS	VT AIS (AIS-V)
VC	SPE
VC4	STS3C SPE
Virtual Container (VC)	Synchronous Payload Envelope (SPE)

NOTE: VC is an ETSI abbreviation for Virtual Container and an ETSI / ANSI abbreviation for (ATM) Virtual Channel. The context of VC must therefore be taken into account when converting between standards.

Index

A

- Accessories, 13
 - J7281A, DCC port converter cable, 14
 - J7283A, FC/PC optical connector, 14
 - J7284A, SC optical connector, 14
 - J7285A, ST optical connector, 14
 - J7821A, transit case, 13
 - optical adapters/cables, 14
- Altitude, 17, 35
- Assistance, 15
- Avoiding optical receiver overload, 24

B

- Back-to-Back functional checks, 41

C

- Certification, 15
- Clock ports, 50
- Cold Start, 56
- Compliance, 31
- Connecting optical cables, 23

Connectors

- 2 Mb/s 2 MHz Clock In port, 50
- 2 MHz Clock Out port, 50
- 52 - 622 Mb/s Optical In port, 49
- 52 Mb/s - 2.5 Gb/s 1310 nm port, 49
- 52 Mb/s - 2.5 Gb/s 1550 nm port, 49
- 9.95/10.71 Gb/s Optical In port, 49
- 9.95/10.71 Gb/s Optical Out port, 49
- DCC/GCC/Trigger ports, 51
- DS1 Clock Input port, 50
- DS1 Clock Out port, 50
- external protective earth terminal, 55
- GPIO port, 55
- Jitter In/Out and Binary Interfaces, 52
- keyboard port, 53
- LAN 10M/100M port, 54
- mouse port, 53
- optical in (SDH/SONET/OTN), 49
- optical out (SDH/SONET/OTN), 48
- rear, 55
- RS232 port, 53
- side panel, 48
- TX Eye Clock 10 Gb/s, 50
- TX Eye Clock 52 - 2488 Mb/s, 50
- USB port, 53
- VGA port, 54

- Covers - how to remove, 38

D

- DCC/GCC/Trigger ports, 51
- Declaration of Conformity, 32
- Dimensions, 18
- Disconnecting optical cables, 24
- Disk drive location, 53

E

- Electrical interfaces, 12
- Electrical test ports (SONET/SDH), 52
- Electromagnetic Compatibility, 32
- Electrostatic discharge (ESD)
 - precautions, 25
- Environment, 34

- Ethernet over SDH
 - Options, 12
- Ethernet over SONET
 - Options, 12
- Eye clock ports, 50

F

- Floppy disk drive (location), 53
- Front panel soft recovery (cold start), 56
- Fuses, 36

G

- GCC port, 51
- General Information, 15
- Getting Started, 33

H

- How to
 - remove instrument covers, 38
- Humidity, 35

I

- Initial Inspection, 34
- Installation, 33
- Instrument cold start/reboot, 56
- Instrument covers - How to remove, 38
- Instrument serial number, 16

L

- Laser product classification, 23
- Laser warning symbols, 24

M

- Mainframe test rate capability, 11

N

- Noise Declaration, 32

Index

O

- Operating Environment, 34
- Operator maintenance
 - general, 28
- Optical cables
 - connecting, 23
 - disconnecting, 24
- Optical connector safety information, 22
- Optical connectors, 13
 - cleaning, 28
- Optical In connectors (SDH/SONET/OTN), 49
- Optical interfaces, 11
- Optical Out connectors (SDH/SONET/OTN), 48
- Optical patch cord, 41
- Optical receiver overload, 24
- Options
 - certificate of calibration, warranty, service plans, 13
 - electrical interfaces, 12
 - Mainframe test rate capability, 11
 - Optical connectors, 13
 - optical interfaces, 11
 - option guide, 10
 - OTN Testing, 12
- Original packaging, 17

P

- Packaging, 17
- Power Cable, 37
- Power Requirements, 35
- Precautions for service engineers, 25
- Preparation for Use, 35
- Product description, 8

R

- Removing the Instrument Covers, 38
- Repackaging for Shipment, 17
- Requesting support, 38
- Responsibilities of the Customer, 15

S

- Safety Information, 19
- Safety symbols, 20

- Serial number, 16
- Shipping/transit to customer sites, 17
- SMA connectors
 - cleaning, 29
- Soft Recovery, 56
- Statement of Compliance, 31
- Storage and Shipment, 17

T

- Technical specifications, 48
- Temperature, 17, 34, 35
- Transit case, 13
- Trigger ports, 51

V

- Ventilation requirements, 35

W

- Weight, 18

In This Book

This book contains installation information for the OmniBER OTN instrument.

Printed in U.K. 08/03
J7230-90054



Agilent Technologies